

SUPPLIED WITH BUNA-N O'RING SEAL

POF-0300H

PAGE  
1

LGB-0125 GUIDE BRACKET  
NON-CORROSIVE  
300 SERIES SST

POF-0300V FLANGE  
65-45-12 DUCTILE IRON  
FITS STANDARD 3" ANSI FLANGES.  
USABLE WITH 1" & 1 1/4"  
GUIDE RAILS.

PAF-0300  
PUMP ADAPTER FLANGE  
3" NPT THREAD  
2" NPT VERSION AVAILABLE  
NON-CORROSIVE  
300 SERIES SST

CP-0300  
CLAMP PLATE  
NON-CORROSIVE  
300 SERIES SST

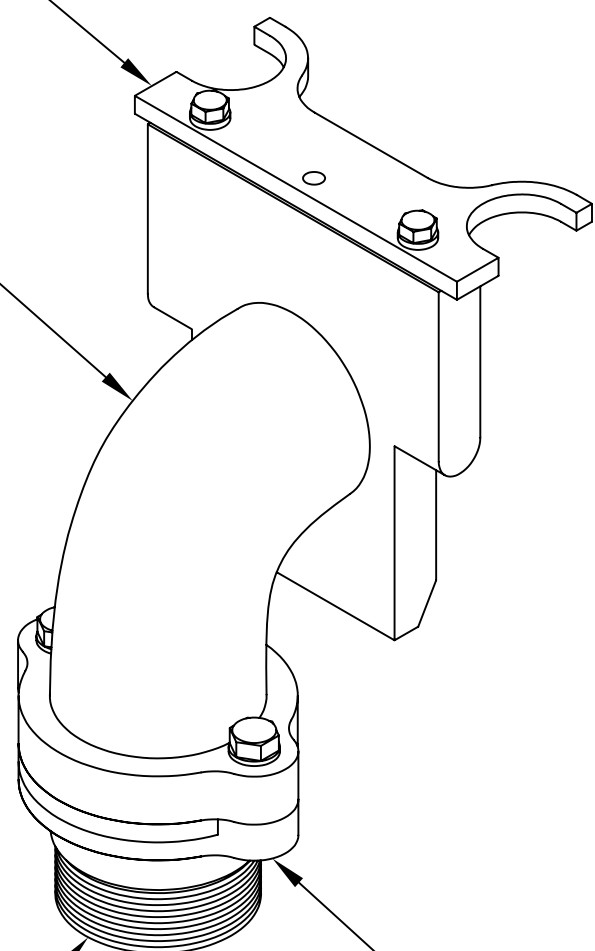

ALL INFORMATION CONTAINED IN THIS DRAWING IS  
CONFIDENTIAL AND PROPRIETARY TO CONERY MFG, INC.

CHANGES	TOLERANCES	DRAWN BY	DATE	SPECIFICATION SHEET DIMENSIONAL DATA	
F	DECIMALS .XXX = ±.005 .XX = ±.010 FRACTIONAL X/X = ±.1/64 ANGLES X° = ±1/2°	D. MIDDLETON	03/17/07	SCALE:	PART NO.
E		MATERIAL SPECIFICATION:  AS NOTED		1/4	PULL-OUT FLANGE
D					
C					
B					
A					